

Technical Data

| | |
|-------------------------|--|
| Application | Egress, side hung |
| Stack Height (mm) | 13 & 17 |
| Size (inches) | 12 & 16 |
| Max. Sash Weight (kg) | Contact the Mila technical team on 01327 707 300 |
| Material Specification: | |
| Tracks | 430 stainless steel |
| Links | 430 stainless steel |
| Rivets | 302 stainless steel |
| End Moulding | Zinc die cast |
| End Spacer | Nylon 6 |
| Box Quantity | 25 |

Technical Drawings

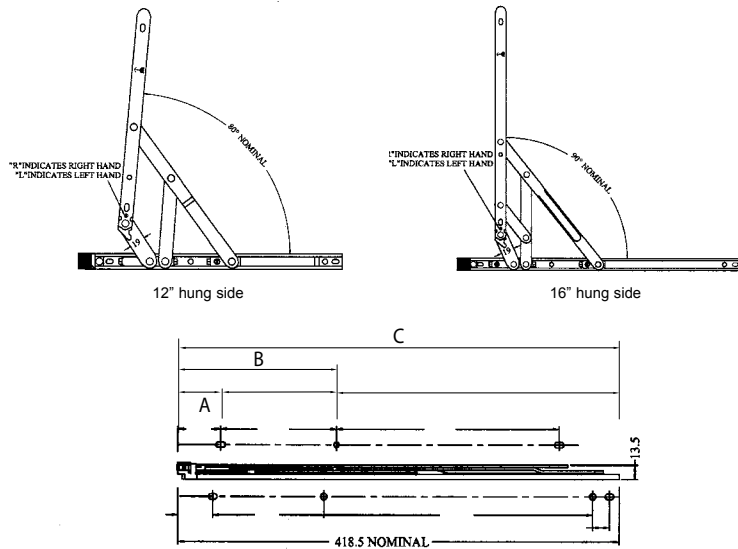

Fixing Hole Details

| Description | A(mm) | B(mm) | C(mm) |
|---------------|-------|-------|-------|
| Side Hung 12" | 37.2 | 79.2 | 220.2 |
| Side Hung 16" | 37.2 | 142.7 | 355.2 |

Trinity Egress Friction Stay

The Trinity egress stay opens to almost 90° for emergency egress.

- Stainless steel friction stays for side hung egress applications
- Almost 90° opening for easy egress
- Allows casement windows (dependent upon size) to satisfy the egress requirements of Document B of the Building Regulations, ie:

“ For emergency egress any window should have an unobstructed openable area that is at least 0.33m square and at least 450mm high and 450mm wide ”
- Handed nylon end-cap for smooth operation and accurate location
- Available in both 13mm & 17mm stack heights to suit most common casement profiles
- Both 12" and 16" sizes available



Recommended Maximum Sash

| Description | Size (") | Width (mm) | Height (mm) | Opening (°) |
|-------------|----------|------------|-------------|-------------|
| Side Hung | 12 | 600 | 300 min | 80° |
| Side Hung | 16 | 700 | 400 min | 90° |

Part Numbers

| Description | Size (") | 13mm Stack Height | 17mm Stack Height |
|-------------|----------|-------------------|-------------------|
| Side Hung | 12 | 023432C | 023482C |
| Side Hung | 16 | 023436C | 023486C |

Guarantees & Accreditations

| | |
|----------------------|----------|
| Mechanical Guarantee | 10 years |
| Labour Guarantee | 2 years |

to place your order simply call our sales team direct on 01327 312 400